

## sat-nms LRXD44 DC LNC Power Supply / L-Band Distributor

The **sat-nms** LRXD44DC provides the redundant supply voltage for 4 Low Noise Converters (LNC) through a separate DSUB-9 connector and distributes the receive signals to four L-band output ports which can be used in the satellite ground station or the cable head end. With 4 output ports a lot of applications can be covered. If you need more output ports, consider the **sat-nms** LRXD28 models. The **sat-nms** LRXD44 is a compact 19" based design with only one rack unit height. So it fits also in applications where no space is left anymore in the 19" rack.

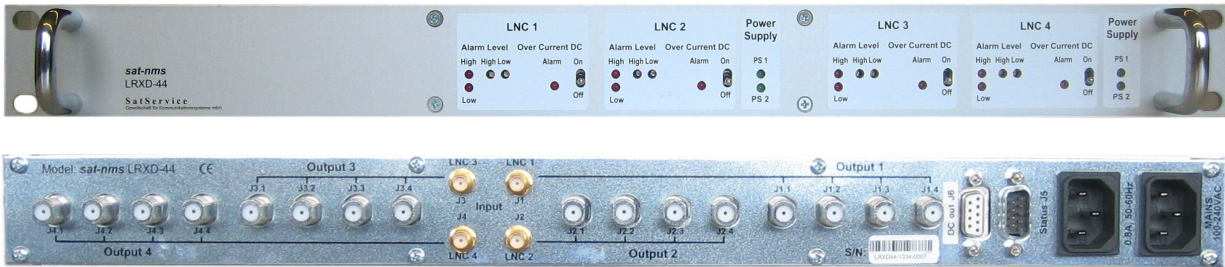

The technology is based on the successful LRXD18 and 28 design. The signal distribution is realized with cascaded Wilkinson dividers which guarantee good frequency response and isolation between the different output ports. Internal L-band amplifiers compensate the loss of the distribution circuit and provide gain compensation. The inputs are assembled with 50Ohm SMA connectors and the outputs are assembled with 75Ohm F connectors. The power for the LNCs is supplied via the DSub 9 female connector.

Each DC output port towards the LNC is electronically over-current protected, so no fuse in the LNC supply has to be exchanged in case of a short circuit with the cable.

The unit includes two power supplies with two independent mains voltage input connectors. Internal redundancy switchover between the two power supplies improves the availability of the unit.

As with the other **sat-nms** L-band distributors Monitoring & Control is available via relay contacts and provides as summary alarm the alarm information of the power supplies and LNC current min/max.

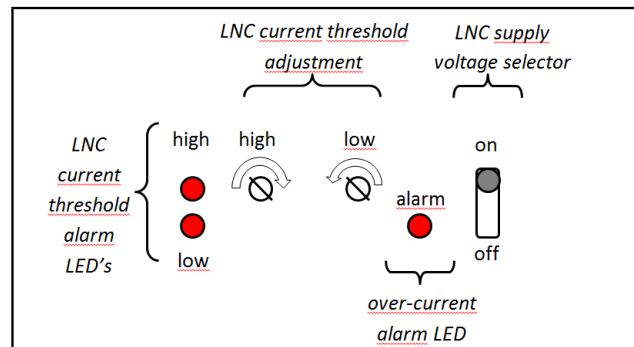

### Key Features

- 19" 1 RU compact design
- 4 LNCs bias current supply in one 19" unit
- 4 L-band output ports per LNC
- LNCs power supply via DSUB-9 female connector
- Redundant power supplies
- Electronic over-current protection
- LNC current monitoring
- High and low current alarms at front panel
- Adjustable LNC current alarm threshold
- Relay contact outputs for all alarms
- Alarms can be used for redundancy switching

### Applications

- In any type of satellite ground stations
- SNG stations and teleports
- Cable head end stations

### Contact Information

SatService  
Gesellschaft für Kommunikationssysteme mbH

Hardstrasse 9,  
D-78256 Steisslingen, Germany

phone +49 7738 97003  
fax +49 7738 97005  
e-mail info@satservicegmbh.de

[www.satnms.com](http://www.satnms.com) [www.satservicegmbh.de](http://www.satservicegmbh.de)

## Technical Specification

### RF Specification

Frequency range	950 to 2150MHz
Input Connectors	SMA female 50Ohm (4)
Input Return Loss	> 15dB
Input Noise Figure	<10dB
Damage input level	+13dBm
Absolute gain from input to output for standard version	-0dB +/-1dB
Relative gain frequency variation in frequency band	+/-1dB
Gain frequency characteristics in any 36MHz band	+/-0,3dB
Group delay in any 36MHz band	< 4ns
Intermodulation with two -13dBm input signals each (total input power -10dBm)	-40dBc
Output Connectors	75Ohm F connectors (16)
Output Return Loss	> 15dB
Isolation between outputs	> 25dB

### LNC Remote Feed

LNC supply voltage, switch able / maximum current per LNC	15V / 500mA
Maximum Total Current for all 4 LNCs	1400mA
DC output connector J6	DSUB9 female

### Alarm Interface

Alarm Interface J5 consists of:	DSUB9 male, Relay Contacts
- Power supply alarm	7-8 open on Alarm 8-9 closed on Alarm
- LNC1, 2, 3 and 4 current threshold alarms output,	LNC1: 1-5 open on Alarm LNC2: 2-5 open on Alarm LNC3: 3-5 open on Alarm LNC4: 4-5 open on Alarm
- each alarm contact provides combined (logical OR) high and low current alarm	
Current high threshold adjustment range	150..500mA
Current low threshold adjustment range	50..500mA
Over-current (DC-switched off)	800mA

### Electrical and Mechanical Specification, Environmental Conditions

Supply voltage	90 to 240V AC 50 to 60Hz
Connector for the two mains voltage AC inputs	IEC
Power consumption including LNC supply	2x35VA
Temperature range	5° to 50° C
Humidity	up to 90% non condensing
Mechanical size	436 x 184x370 mm, 19" 1RU
Weight	5 kg

## Installation instructions

- Switch LNC supply voltage on/off for LNCs with dip-switch on front panel
- Connect LNCs on J1, J2, J3 and/or J4
- Connect receivers to
  - J1.1 ... 1.4
  - J2.1 ... 2.4
  - J3.1 ... 3.4
  - J4.1 ... 4.4
- Connect Monitoring Status Connector J5 (for details see pin layout drawing)
- Connect DC cable on J6 (for details see pin layout drawing)
- Connect 2x mains voltage

